

## Flexem 6000series HMI IoT Expanding Modules

### FLink Series



### Products Overview

FLink series expanding module is the FE6000 series IoT HMI spare parts. Through adding the IoT accessories, traditional FE6000 series HMI can be changed into IoT HMI which supports remote monitoring. On-site PLC and HMI data remote monitoring, program remote downloading and remote maintenance. It supports various Ethernet and IoT cloud products. Without any batteries, FLink cannot work separately, it must be used together with FE6000 series HMI. FLink module shall be insert HMI back IoT expanding slot.

## Installation Scheme

### FLink Module Installation:

After HMI is powered off, open the HMI back cover IoT module as indicating in photos and insert the FLink into card slot.

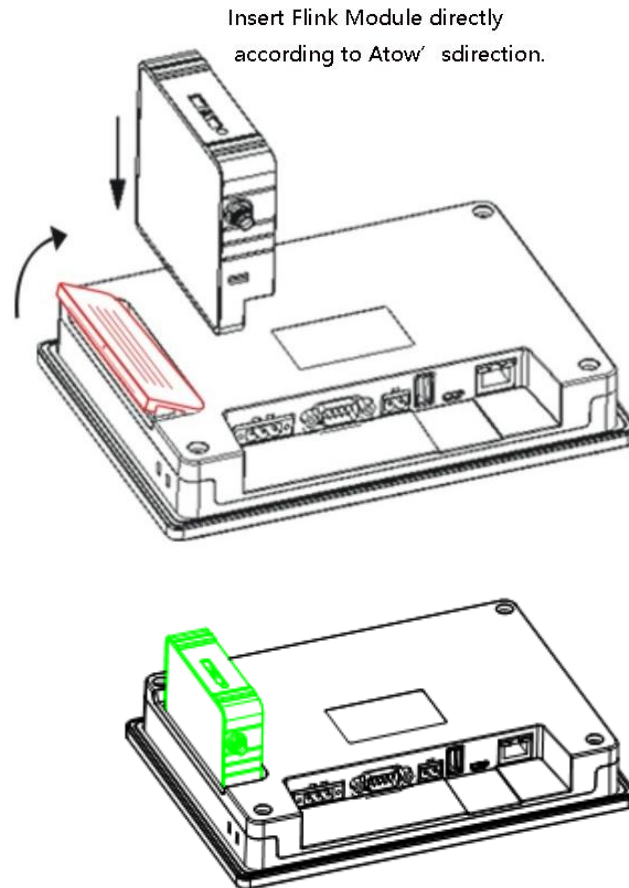

1. 2G/4G version FLink module, it needs install SIM card as below: slim screw is needed to install it in the hole, SIM card can be popped up automatically and placed as in the photo. After it inserts inside completely, cover will be sink a little.

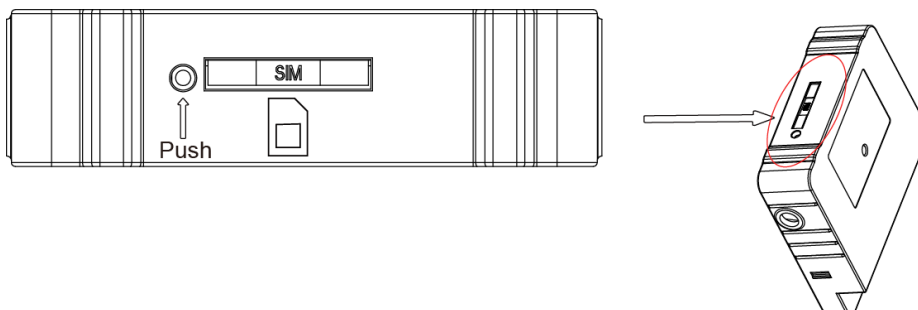

## Specifications

		FLink	FLink-2G/FLink-2G-A	FLink-4G/FLink-4G-A	FLink-WiFi/FLink-WiFi-A
H a r d w a r e	Network Access	Ethernet	Ethernet/Mobile/Unicom 2G	Ethernet/Mobile/Unicom/Telecom 2G/3G/4G	Ethernet/WiFi
	Network Frequency		GSM850/EGSM900/DCS1800/PCS1900	LTE FDD:B1/B3/B5/B8 LTE TDD: B38/B39/B40/B41 WCDMA: B1/B8 TD-SCDMA: B34/B39 CDMA: BC0 GSM:900/1800MHz	IEEE802.11b/g/n compatible WLAN IEEE 802.11e QoS Enhancement (WMM)
	Applicable Model	FE6070H FE6100CE	FE6070C FE6070H FE6100C FE6100CE	FE6070C FE6070H FE6100C FE6100CE	FE6070C FE6070H FE6100C FE6100CE
S o f t w a r e	VPN Transmission	Not Available		Available (only for FE6000Series products with Ethernet)	
	Data Monitor	200	200	300	300
	Alarming Push	60	100	100	100
		It supports clients push, SMS push(20 items free each day),wechat public NO push.			
	Historical Data	20	30	30	30
		It supports offline transfer, each point can store 5w items during offline, and the data can be kept for 90 days in the cloud.			
	Edge Computing	Available			
Network Protocol	It supports over 100 industrial devices protocols.				
Manage Maintenance	It supports firmware remote upgrading, and equipping files leading in/out.				
M e c h a n i c	Dimension	68*74*19.5mm(without antenna),68*81.1*19.5mm(antenna external)			
	Material	ABS Engineering Plastic			

Note: FLink web version, using HMI ports to get onto the Ethernet. If the HMI is without any Ethernet ports, FLink web version cannot be used.

FLink is prohibited to plug in/out with power. FLink can be plugged only during HMI powering off.

## Parameters Setting

Parameters setting is needed by using FLink module, the software needed: FStudio configuration software, FBox PC Client remote monitoring setting file.

Software downloading link: <http://www.flexem.com/download.html>

- **Start FLink expanding module**

FLink module shall be selected when establish FE6000 series HMI software in FStudio. Or you can open existing projects entering HMI setting page, then click using FLink module to choose the correspondent model.

If you did not set using FLink in HMI configuration projects, then FLink will not work normally.

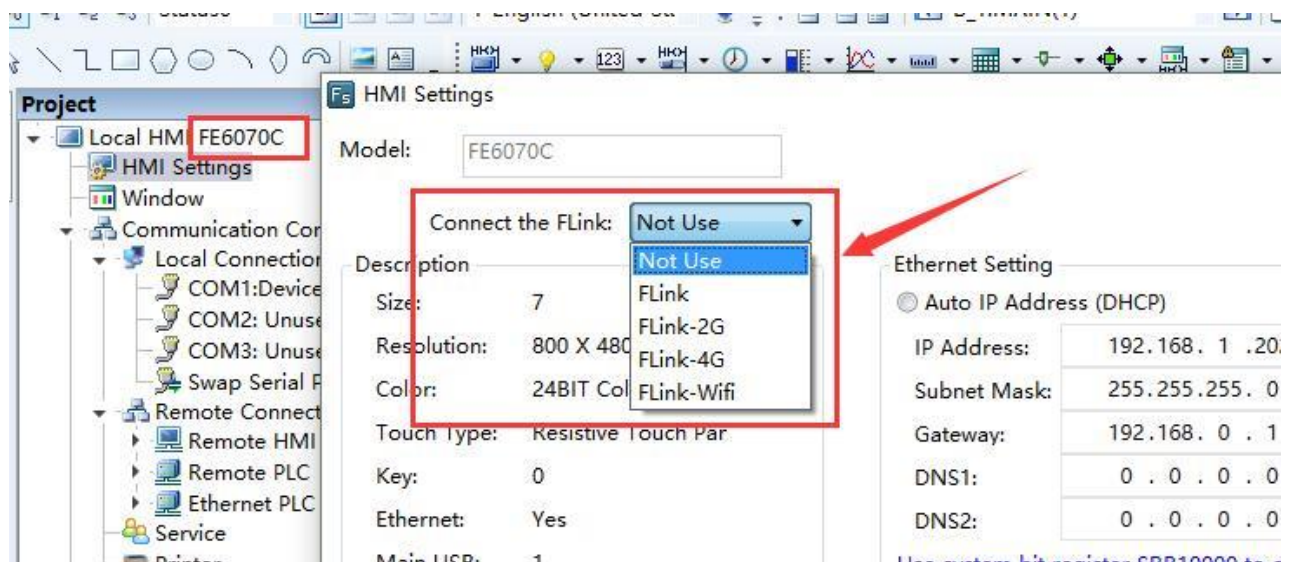

- **Set Ethernet Connection**

You can select FLink accessing Ethernet module, and you need click FLink accessing Ethernet ways when using mobile card or WiFi.

### Using GPRS/3G/4G/WiFi Remote Connection

You need set according to devices network conditions on site when using Ethernet. Site network supports IP address distributing going to Ethernet, you can set automatic getting IP address(DHCP).Site network needs fixed IP going to Ethernet, then please set static IP and fill designated IP, subnet mask and gateway.

### WiFi setting

You need set searching and SSID and password of WiFi using WiFi, and you need use special setting tools for setting.

Setting tools can be pulled out from FBoxClient, Client can be set in the left below corner, client left below setting-FBox setting tools, please check the below image:

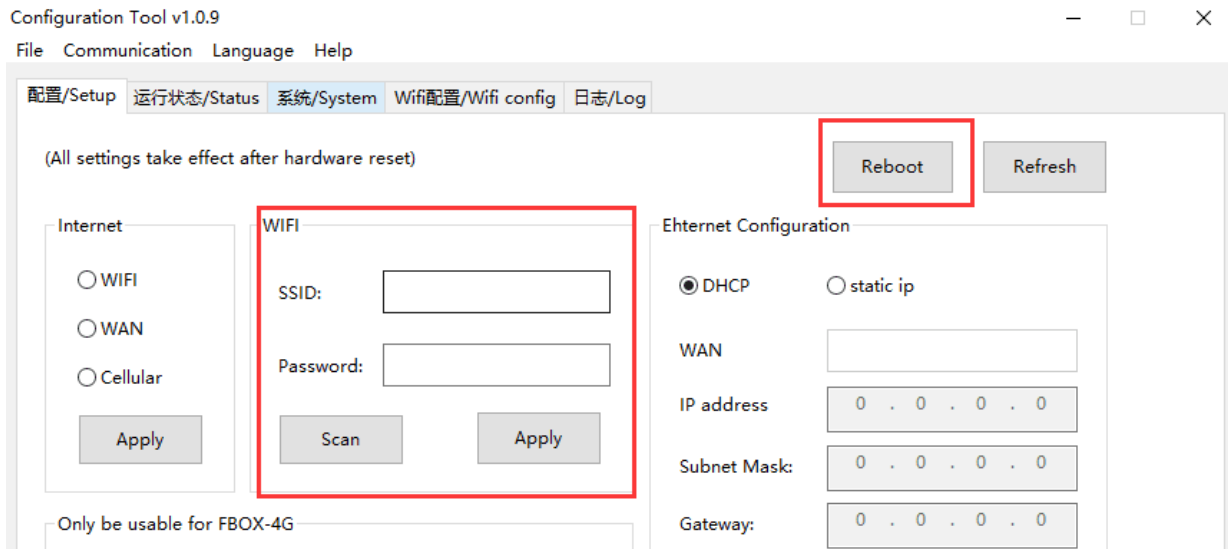

Please click "Scan", select needed SSID, after writing correspondent password, click "Apply", then click "Reboot". After HMI finished restarting, then it can be online.

Note:

FLink-WiFi only supports connecting WPA2-PSK password hotspot, and does not support connecting no password hotspot. SSID in the WiFi does not support Chinese characters.

#### ● 4G Network APN Setting

**4G Network APN** usually does not need setting, and this function can be used only when APN is required when using SIM card, or APN needs setting in your devices area. You can inquire your SIM card operator for APN information.

Correspondent parameters can be filled in the tools setting page, and it will be effective after re-start.

Only be usable for FBOX-4G

APN:	<input type="text"/>	Set APN
User:	<input type="text"/>	
Password:	<input type="text"/>	Set UserPassword
Dial:	<input type="text"/>	Set dial number

( Example: "\*\*99\*\*\*1" or "\*\*99" )

- **Remote Clients Setting**

After FLink starts and setting online, you can use FLink in FBox PC Client software. The exact using methods can be referred to FBox series products user manual. The downloading link:

<http://www.flexem.com/download.html>

The devices drive for setting communication needs to be processed in FStudio software. FBox Client only can view the drive but cannot modify the drive. The exact using can be referred to FStudio user manual. The downloading link: <http://www.flexem.com/download.html>

- **Notice of changing FLink**

As the server only recognize FLink serial NO, the devices drive information connected by HMI will be uploaded to new FLink serial NO in the server when Flink needs to be changed. The data table information of remote setting and JS script code needs re-writing or lead in from old FLink.

## Size

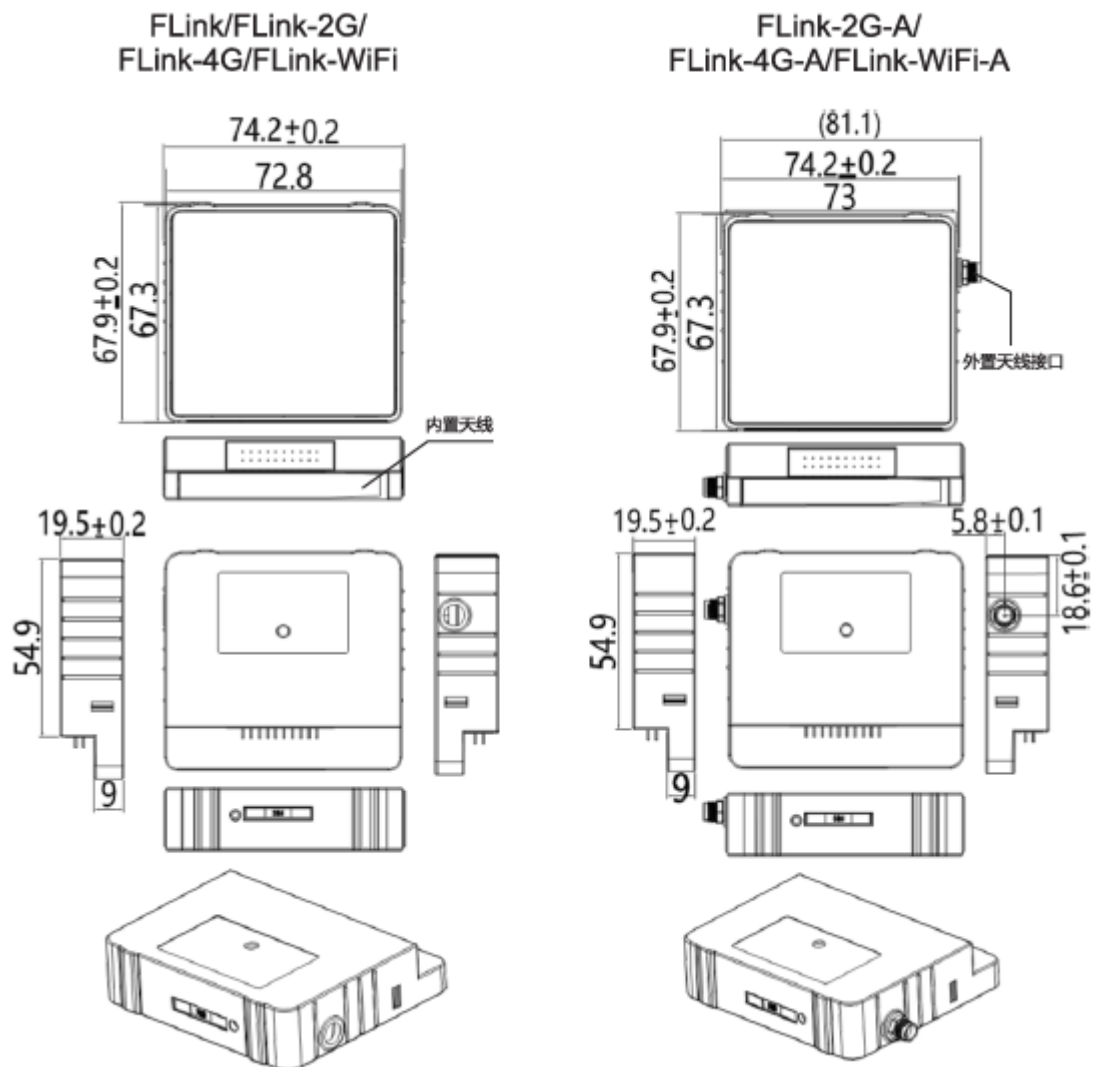

## Contact Us

---

### Shanghai (R&D Center)

Address: Room 804, Lane 1688, North  
Guoquan Road, Yangpu  
District, Shanghai, China  
Telephone: +86-21-68683993  
Fax: +86-21-65107569

### Suzhou

Address: Room 915, Ricky Building,  
No.668,Yuting Avenue,Suzhou  
Industrial Park  
Telephone: +86-512-69833996

### Shenzhen (Factory)

Address: 5th Floor, NO.2 Building,  
Lanyun Science Park, Tangtou  
Road, Shiyan Town, Baoan  
District, Shenzhen, China  
Telephone: +86-755-27610682  
Fax: +86-755-27629895

### Wuxi

Address: Room 1603, Taihu  
Mingzhu Development  
Building, No. 1890 Taihu  
West Road, Binhu  
District, Wuxi City  
Telephone: +86-18505101982

### Beijing

Address: Room 2008, Building 1, No. 93  
Jianguo Road, Chaoyang  
District, Beijing (Wanda  
Plaza),China  
Telephone: +86-10-58204608  
Fax: +86-10-58204608

### Hangzhou

Address: Room 1005, Building 6,  
Dongsha Mingcheng, No.  
159, Tiancheng East  
Road, Xiasha  
Development Zone,  
Hangzhou